



LADDER & ACCESS EQUIPMENT



Team Step	96
Monstar Step.....	97
Monstar Ladders	98-100
Platform Ladders.....	102-104
Double Sided Ladders	105
Extension Ladders.....	106
Order Picking Ladders.....	107
Warehouse & Mobile Platforms	108
Mezzanine Access & Lifts	109
Work Platforms	110

TEAMSTEP



visit www.teamstep.com.au for the latest information & details on all our TeamStep products.

STEP UP®
"Strongest & Safest Unit in the Market"

Large Deck Size 370mm x 370mm.
Fitted with Non-Slip Tape.
Four Way Access.
Standard with Rubber Feet

Available in Orange & Yellow.

- SCHOOLS • OFFICE • WAREHOUSE & RETAIL



Model	Size	Height	Capacity	Weight
TSSU	370 x 370mm	370mm	260kg	5.0kg

TEAMSTEP

MOBILE TEAMSTEP®
"Always a Step Above"

Totally Mobile.
Anti-Slip Surface.
Lightweight, durable one piece construction.
Stackable.
No rusting or dangerous sharp edges.
Castors are spring loaded to retract when TEAMSTEP is in use.
Fitted with Non-Slip Tape.
Made of Rotomoulded Plastic.

Available in Blue & Yellow

- SCHOOLS • OFFICE • WAREHOUSE & RETAIL



Model	Size	Height	Capacity	Weight
TSTS	315mm	395mm	180kg	4.2kg

TEAMSTEP

JUMBO TEAMSTEP®
"Best of Both Worlds"

All the benefits of the TEAMSTEP® but with the large deck size of the Square STEP-UP®
Totally Mobile.
Anti-Slip Surface.
Lightweight, durable one piece construction.
Stackable.
Castors are spring loaded to retract when TEAMSTEP is in use.
Fitted with Non-Slip Tape.

Available in Yellow.

- OFFICE • WAREHOUSE • SHOP • SCHOOLS
- IDEAL FOR TRADESPEOPLE



Model	Size	Height	Capacity	Weight
TSJUMBO	375mm	355mm	180kg	4.2kg

MONSTAR STEP

www.monstarladders.com.au

PRODUCT UPGRADE

Outperforms other similar safety steps in longevity and strength.

The all new Monstar Step is the only plastic safety step that has superior design features over existing injection moulded safety steps available in Australia.

The Monstar Step is a quality, cost effective solution designed for intermittent use. Designed to be durable, safe and robust.

Monstar Step has a larger, safer area of non slip tape including an indentation on the lower step so the tape will not wear away - ensuring longevity of non slip surface.

The Monstar Steps come with the following features, benefits and specifications.

- Large Deck Size - 370mm x 370mm.
- Fully Fitted with Non-Slip Tape.
- Four Way Access.
- Rubber Feet.



- LARGE DECK SIZE 370 x 370MM
- LOAD CAPACITY 260KG RATED
- LIGHTWEIGHT WITH 3.5KG ONLY

MONSTAR STEP

Model	Deck Size	Height	Capacity	Weight
MONSTEP	370 x 370mm	375mm	260kg	3.5kg



Built-in Rubber Feet



Four Way Non-Slip Access



Fully Fitted With Non-Slip Tape

LITTLE MONSTAR

www.monstarladders.com.au

PRODUCT UPGRADE

Compact Step Ladder designed for safe, easy and efficient use for a wide range of applications.

A range of Compact Step Ladders designed and manufactured to meet the highest demanding applications in Australia. These ladders are built with industry rated material for moderate to high level use.

- 150kg Load Rating.
- Lightweight, Manoeuvrable and easy to use.
- Rear Roller Castors for ease of movement.
- Heavy Duty Tread for added safety on all steps.
- Strong Safety Bracket including recess for Storing Tools and Bucket Hooks.
- Light, Strong, Aluminium Construction.



- ALUMINIUM
- 150KG HEAVY-DUTY
- LIGHTWEIGHT

150kg Compact Step Ladder

Model	Type	Footprint	Top Step Height	Safety Bracket Height	Dimensions	Weight
MONLM2	2 Step	620 x 530mm	480mm	480mm	900 x 550 x 150mm	6kg
MONLM3	3 Step	900 x 550mm	680mm	480mm	1200 x 580 x 150mm	8kg
MONLM4	4 Step	1180 x 550mm	910mm	760mm	1500 x 580 x 150mm	9kg

MONSTAR LADDER

www.monstarladders.com.au

PRODUCT UPGRADE

Strong, Lightweight Platform Ladder designed for Heavy Duty Industrial use.

A range of Platform Ladders designed and manufactured to meet the highest demanding applications in Australia.

These ladders are built with industry rated material for moderate to high level use.

- Fully Welded Construction.
- Checkerplate Platform.
- Wide Base with Rubber Feet.
- 700mm x 400mm Platform
- Exceeds AS/NZS 1892.1.
- Standard Work Platform.
- Fully Welded Retractable Castors.
- Optional Handrails Available.



Safety Gate



Folded Ladder



Stronger Constructure

- ALUMINIUM
- 150KG HEAVY-DUTY
- LIGHTWEIGHT



Safety Bar

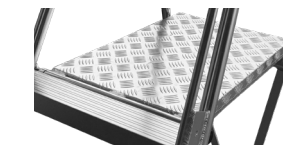

Large Platform



Castor Wheels

150kg Platform Ladder

Model	Type	Footprint	Platform Height	Total Height	Dimensions	Weight
MONSTAR2	2 Step	1040 x 720mm	570mm	1440mm	1450 x 720 x 200mm	9kg
MONSTAR3	3 Step	1230 x 720mm	850mm	1720mm	1720 x 720 x 200mm	11kg
MONSTAR4	4 Step	1420 x 720mm	1130mm	2000mm	2000 x 720 x 200mm	13kg
MONSTAR5	5 Step	1610 x 720mm	1410mm	2280mm	2260 x 720 x 200mm	15kg
MONSTAR6	6 Step	1810 x 720mm	1690mm	2560mm	2530 x 720 x 200mm	17kg

HR - OPTIONAL HAND RAIL

MONSTAR LADDER

www.monstarladders.com.au

PRODUCT UPGRADE

Designed for easy, efficient use in warehousing and workplace environments.

Monstar Order Picking Ladders provide safe and secure access to all your elevated stock.

All Monstar Order Picking Ladders feature a huge 585mm x 730mm work platform, retractable safety castors and a 150kg Rated Capacity, reinforced with a strong welded construction.

The Monstar Order Picker is guaranteed to make stock picking safer and more efficient for your business.

- ALUMINIUM
- 150KG HEAVY-DUTY
- LIGHTWEIGHT

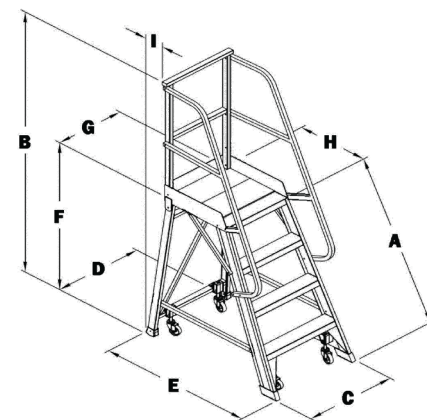

- Made to AS/NZS 1892.1.
- Spring Loaded Castors.
- Safety Gate for Security and Stability at Elevated Heights.
- Designed for use on Commercial Sites and Warehouses.
- Light, Strong, Aluminium Construction with Ribbed Tread.
- Fully Welded Construction.
- Lightweight, Manoeuvrable & easy to use.

150kg Order Picker Ladder

Model	Type	A	B	Footprint C x E	D	F	G	H	I
MONOP2	2 Step	620mm	1466mm	675 x 1025mm	659mm	565mm	585mm	730mm	17mm
MONOP3	3 Step	927mm	1742mm	715 x 1167mm	695mm	840mm	585mm	730mm	37mm
MONOP4	4 Step	1222mm	2017mm	758 x 1305mm	735mm	1115mm	585mm	730mm	60mm
MONOP5	5 Step	1524mm	2290mm	800 x 1460mm	775mm	1390mm	585mm	730mm	87mm
MONOP6	6 Step	1812mm	2570mm	844 x 1595mm	815mm	1665mm	585mm	730mm	112mm



INDALEX Industrial Aluminium Slimline Platform Ladder - 120kg

Special slim ladder, lightweight, easy to store. Strong construction with aluminium hinge & connection between steps. TRDP5/2 - TRDP7/4 fold to just 40mm thick. Impressive 150kg load rating on TRDP8/5. Industrial duty rated. Designed for use on industrial work sites. Light, strong, aluminium construction. Double sided for greater versatility and greater load bearing strength. Anti-slip feet for added safety & stability. Made to Australian & New Zealand standards AS/NZS 1892. 1 Year warranty.

TRDP5/2 & TRDP7/4 FOLD TO JUST 40mm THICK!

Model	Type	Overall Height	Platform Height	Weight
TRDP5-2	2 Step	1520mm	600mm	5.6kg
TRDP6-3	3 Step	1830mm	900mm	6.9kg
TRDP7-4	4 Step	2130mm	1200mm	8.3kg
TRDP8-5	5 Step	2400mm	1500mm	11kg



BAILEY Industrial Aluminium Retail & Office Platform Stepladder - 120kg

Large 300mm deep and 350mm wide platform provides a comfortable work position. Industrial Duty Rated and designed for use on industrial work sites where strength, durability and safety is required. 120kg load rating. Trapezoidal tread profile for strength and durability. 115mm deep when closed makes it easy to store when not in use. Made to Australian & New Zealand standards AS/NZS 1892. 1 Year warranty.

Model	Type	Rech Height	Platform Height	Weight
FS13868	2 Step	2600mm	570mm	4.5kg
FS13869	3 Step	2900mm	850mm	5.6kg
FS13870	4 Step	3100mm	1130mm	6.9kg



INDALEX Aluminium Platform Ladder - 150kg

Industrial duty rated, heavy duty 150kg load rating. Anti-slip large extruded work platform and rubber feet for added safety and stability. Made to Australian & New Zealand standards AS/NZS 1892. Platform work area - 660mm x 400mm and solid 900mm high guard rail.

Model	Type	Platform Height	Weight
PROP5-2	2 Step	600mm	11.0kg
PROP6-3	3 Step	900mm	12.0kg
PROP7-4	4 Step	1200mm	13.0kg
PROP8-5	5 Step	1500mm	14.0kg
PROP9-6	6 Step	1800mm	16.0kg
PROP10-7	7 Step	2100mm	20.0kg
PROP11-8	8 Step	2400mm	22.0kg
PROP12-9	9 Step	2700mm	24.0kg
PROP13-10	10 Step	3000mm	26.0kg
PROP15-12	12 Step	3600mm	30.0kg



Also available - wheel kits, locking gates, hand rails, tool tray and heavy duty top shelf.

LADDER & ACCESS EQUIPMENT

LADDER & ACCESS EQUIPMENT

BAILEY

BAILEY P170 Job Station Aluminium Platform Stepladder - 170kg

Huge Platform Area (610 x 457mm).
Extra Strong, Heavy Duty Aluminium Construction.
New 'Trapezoidal Tread Design' provides an incredibly strong tread to stile joint.
Fully Integrated Bracing and Castor System.
Made to Australian & New Zealand standards AS/NZS 1892.

Model	Type	Platform Height	Maximum Reach	Weight
FS13538	3 Step	900mm	2870mm	16.9kg
FS13539	4 Step	1200mm	3160mm	18.4kg
FS13540	5 Step	1500mm	3450mm	19.9kg
FS13541	6 Step	1800mm	3740mm	21.9kg
FS13542	7 Step	2030mm	4030mm	27.4kg
FS13543	8 Step	2320mm	4320mm	28.4kg
FS13544	10 Step	2910mm	4910mm	33.2kg
FS13545	12 Step	3490mm	5490mm	37.6kg
FS13954	Optional Safety Gate Kit			2.4kg



BAILEY

BAILEY P170 Job Station Fibreglass Platform Stepladder - 170kg

Large 610 X 457mm platform for added safety and all day standing comfort.
Electro-safe fibreglass design makes it suitable to use where an electrical hazard exists.
Anti-slip PVC boots for added stability.
Multi-function handrail for tool storage.
Made to Australian & New Zealand standards AS/NZS 1892.

Model	Type	Platform Height	Maximum Reach	Weight
FS13530	3 Step	900mm	2870mm	16.9kg
FS13531	4 Step	1200mm	3160mm	18.4kg
FS13532	5 Step	1500mm	3450mm	19.9kg
FS13533	6 Step	1800mm	3740mm	21.9kg
FS13534	7 Step	2030mm	4030mm	27.4kg
FS13535	8 Step	2320mm	4320mm	28.4kg
FS13536	10 Step	2910mm	4910mm	33.2kg
FS13537	12 Step	3490mm	5490mm	37.6kg
FS13954	Optional Safety Gate Kit			2.4kg



BAILEY

BAILEY P150 Riveted Aluminium Platform Stepladder - 150kg

Lightweight and highly portable.
Fully functional magnetised handrail secures tools and fasteners.
Large standing area (508 x 416mm) adds comfort and stability.
Checker plate deck pattern provides an anti-slip standing area.
Large anti-slip feet for stability and durability.
Made to Australian & New Zealand standards AS/NZS 1892.

Model	Type	Platform Height	Maximum Reach	Weight
FS13580	3 Step	900mm	2900mm	11.0kg
FS13581	4 Step	1200mm	3200mm	12.5kg
FS13582	5 Step	1500mm	3500mm	13.9kg
FS13583	6 Step	1800mm	3800mm	15.8kg
FS13584	Optional Castor Kit			3.5kg
FS13952	Optional Safety Gate Kit			2.6kg



BAILEY

BAILEY P150 Riveted Fibreglass Platform Stepladder - 150kg

Lightweight and highly portable.
Fully functional magnetised handrail secures tools and fasteners.
Large standing area (508 x 416mm) adds comfort and stability.
Checker plate deck pattern provides an anti-slip standing area.
Large anti-slip feet for stability and durability.
Made to Australian & New Zealand standards AS/NZS 1892.

Model	Type	Platform Height	Maximum Reach	Weight
FS13576	3 Step	900mm	2900mm	12.1kg
FS13577	4 Step	1200mm	3200mm	13.8kg
FS13578	5 Step	1500mm	3500mm	15.4kg
FS13579	6 Step	1800mm	3800mm	17.5kg
FS13584	Optional Castor Kit			3.5kg
FS13952	Optional Safety Gate Kit			2.6kg



BAILEY

BAILEY Professional Punchlock Aluminium Platform Stepladder - 170kg

Industrial duty rated, designed for use on industrial work sites.
Made to Australian & New Zealand Standards AS/NZS 1892.1.

Model	Type	Platform Height	Maximum Reach	Weight
FS13931	2 Step	570mm	2570mm	8.8kg
FS13932	3 Step	850mm	2860mm	10.0kg
FS13933	4 Step	1130mm	3140mm	11.1kg
FS13934	5 Step	1420mm	3430mm	12.3kg
FS13935	6 Step	1700mm	3710mm	14.0kg
FS13936	7 Step	1990mm	4000mm	19.5kg
FS13937	8 Step	2270mm	4280mm	21.0kg
FS13991	Optional Castor Wheel Kit (White) Fits 2-5 Step			2.5kg
FS13992	Optional Castor Wheel Kit (Yellow) Fits 6-7 Step			2.5kg
FS13993	Optional Castor Wheel Kit (Green) Fits 8 Step			3.3kg
FS13952	Optional Safety Gate Kit			2.7kg



BAILEY

BAILEY Professional Punchlock Fibreglass Platform Stepladder - 170kg

Large 400 X 500mm platform for added safety and all day standing comfort.
Anti-slip PVC boots for added stability and multi-function handrail for tool storage.
Made to Australian & New Zealand standards AS/NZS 1892.

Model	Type	Platform Height	Maximum Reach	Weight
FS13945	2 Step	570mm	2570mm	11.4kg
FS13946	3 Step	860mm	2860mm	13.1kg
FS13947	4 Step	1140mm	3140mm	14.8kg
FS13948	5 Step	1430mm	3430mm	16.5kg
FS13949	6 Step	1710mm	3710mm	18.7kg
FS13950	7 Step	2000mm	4000mm	24.8kg
FS13951	8 Step	2280mm	4280mm	26.8kg
FS13991	Optional Castor Wheel Kit (White) Fits 2-3 Step			2.5kg
FS13992	Optional Castor Wheel Kit (Yellow) Fits 4-6 Step			2.5kg
FS13993	Optional Castor Wheel Kit (Green) Fits 7-8 Step			3.3kg
FS13952	Optional Safety Gate Kit			2.7kg





INDALEX Pro Series Industrial Fibreglass Platform Ladder - 150kg

Platform Work Area - 660mm x 400mm.
Solid 900mm High Guard Rail.
Made to Australian & New Zealand standards AS/NZS 1892.

Model	Type	Platform Height	Weight
PROPF5-2	2 Step	600mm	13.0kg
PROPF6-3	3 Step	900mm	14.0kg
PROPF7-4	4 Step	1200mm	16.0kg
PROPF8-5	5 Step	1500mm	17.0kg
PROPF9-6	6 Step	1800mm	20.0kg
PROPF10-7	7 Step	2100mm	24.0kg
PROPF11-8	8 Step	2400mm	26.0kg
PROPF12-9	9 Step	2700mm	28.0kg
PROPF13-10	10 Step	3000mm	30.0kg
PROPF15-12	12 Step	3600mm	36.0kg



Also available - wheel kits, locking gates, hand rails, tool tray and heavy duty top shelf.



INDALEX Riveted Solid Aluminium Double Sided Step Ladder - 120kg, 135kg, 150kg & 180kg

3 Year Warranty for Tradesman and lifetime warranty for Pro Series.
Made to Australian & New Zealand standards AS/NZS 1892.

Model	Type	Capacity	Ladder Size	Weight
TRDS2D	2 Step	150kg	600mm	3.0kg
TRDS3D	3 Step	150kg	900mm	4.1kg
TRDS4D	4 Step	150kg	1200mm	4.9kg
TRDS5D	5 Step	135kg	1500mm	6.5kg
TRDS6D	6 Step	135kg	1800mm	7.4kg
TRDS7D	7 Step	120kg	2100mm	9.2kg
TRDS8D	8 Step	120kg	2400mm	10.0kg
PROS9D	9 Step	180kg	2700mm	14.0kg
PROS10D	10 Step	180kg	3000mm	16.0kg
PROS12D	12 Step	150kg	3600mm	20.0kg
PROS14D	14 Step	150kg	4300mm	25.0kg
PROS16D	16 Step	150kg	4800mm	30.0kg



BAILEY Aluminium Adjustable Height Platform Stepladder - 170kg

3 - 4 - 5 - 6 Step

Adjustable height to cover 4 sizes of platform step ladder. (3 Step, 4 step, 5 step & 6 step).
Single-handed, self-locking mechanism. Enables easy adjustment.
Fully adjustable back-leg approx. 49mm increments enabling product to be used on stairs and sloping surfaces.
Large standing platform 420mm wide x 500mm deep.
Multi-functional handrail for tools and equipment.
Safety gate compatible "pre-drilled ready fit" (fs13952- optional extra).
Light weight for this type of product (18.8kg).
Product is shipped and displayed on shelf with outriggers in the closed position.
On first use the user pulls out the outriggers and they lock permanently into position.
Made to Australian & New Zealand standards AS/NZS 1892.



Model	Step	Nominal Size	Platform Height	Reach Height	Weight
FS13999	3 Step	1860mm	850mm	2850mm	18.8kg
	4 Step	2160mm	1140mm	3140mm	
	5 Step	2460mm	1420mm	3420mm	
	6 Step	2760mm	1710mm	3710mm	



INDALEX Pro Series Fibreglass Double Sided Step Ladder - 150kg & 180kg

Aluminium components have been anodized for better corrosion resistance and lower retention of dirt and grime.
Heavy Duty Fixed Feet for 8ft - 16ft.
5 Year Warranty.
Made to Australian & New Zealand standards AS/NZS 1892.

Model	Type	Capacity	Ladder Size	Weight
PROSF3D	3 Step	180kg	900mm	5.8kg
PROSF4D	4 Step	180kg	1200mm	7.4kg
PROSF5D	5 Step	180kg	1500mm	9.2kg
PROSF6D	6 Step	180kg	1800mm	11.0kg
PROSF7D	7 Step	180kg	2100mm	13.0kg
PROSF8D	8 Step	180kg	2400mm	15.0kg
PROSF10D	10 Step	180kg	3000mm	21.0g
PROSF12D	12 Step	150kg	3700mm	26.0kg
PROSF14D	14 Step	150kg	4300mm	30.0kg
PROSF16D	16 Step	150kg	4800mm	36.0kg



INDALEX PROMT Aluminium Multi-Purpose Ladder

6 Different ladders in 1.
A locking hinge allows the ladder to be positioned in a number of different configurations.
Industrial grade aluminium construction.
Designed for use on industrial work sites.
Rungs utilise a 3-piece rung joint system for greater strength & durability.
Anodized aluminium components for superior corrosion resistance.

Model	Type	Ladder Height - Stairway	Ladder Height - 2 Scaffold Bases	Ladder Height - Twin	Ladder Height - Extension
PROMT11	Extended - 12 Step	1300 - 1500mm	300 - 1200mm	1000 - 1500mm	2000 - 3000mm
PROMT15	Extended - 16 Step	1600 - 2100mm	300 - 1200mm	1300 - 2100mm	2600 - 4200mm
PROMT19	Extended - 20 Step	1900 - 2700mm	300 - 1200mm	1600 - 2700mm	3200 - 5400mm



LADDER & ACCESS EQUIPMENT

LADDER & ACCESS EQUIPMENT



INDALEX Industrial Trade Aluminium Extension Ladder - 135kg

3 Year warranty.
Industrial duty rated. Designed for use on industrial work sites.
Light, strong, aluminium construction.
Double sided for greater versatility and greater load bearing strength.
Anti-slip feet for added safety & stability.
Made to Australian & New Zealand standards AS/NZS 1892.

Model	Type	Ladder Size	Weight
TRDX16	Extended - 16 Step	2900/4700mm	12.5kg
TRDX18	Extended - 18 Step	3200/5300mm	13.5kg
TRDX22	Extended - 22 Step	3800/6600mm	15.5kg



INDALEX Pro Series Aluminium Extension Ladder - 130kg & 180kg

Industrial Grade Aluminium Construction.
Designed for use on industrial work sites.
Rungs utilise a 3-Piece Rung Joint System for greater strength & durability.
Anodized Aluminium Components for superior corrosion resistance.
Made to Australian & New Zealand standards AS/NZS 1892.

Model	Type	Capacity	Ladder Size	Weight
PROX14	Extended - 14 Step	180kg	2600/4100mm	15.0kg
PROX18	Extended - 18 Step	180kg	3200/5300mm	19.0kg
PROX22	Extended - 22 Step	180kg	3800/6600mm	19.0kg
PROX26	Extended - 26 Step	150kg	4400/7800mm	24.0kg
PROX30	Extended - 30 Step	150kg	5000/9000mm	26.0kg
PROX33	Extended - 33 Step	130kg	5600/9900mm	28.0kg
PROX36	Extended - 36 Step	130kg	6300/10800mm	33.0kg



INDALEX Trade Industrial Fibreglass Extension Ladder - 120kg & 135kg

3 Year Warranty.
V-Bracket fitted as standard.
Made to Australian & New Zealand standards AS/NZS 1892.

Available - Optional Retractable Castors/Wheels Kits.
- Optional 'Fold Away' Safety Gate for 2-6 Step Model.

Model	Type	Capacity	Ladder Size	Weight
TRDXF14	Extended - 14 Step	135kg	2800/4300mm	17.0kg
TRDXF18	Extended - 18 Step	135kg	3400/5500mm	21.0kg
TRDXF22	Extended - 22 Step	135kg	4000/6700mm	24.0kg
TRDXF26	Extended - 26 Step	120kg	4900/8200mm	30.0kg



INDALEX Aluminium Order Picking Ladder - 180kg

Durable heavy duty rated industrial aluminium.
Folds easily for storage & transportation.
Front & rear platform gates allow for walk through ability.
Near vertical rear section allows access right up against shelving or truck deck.
Made to Australian & New Zealand standards AS/NZS 1892.

Model	Type	Platform Height	Weight
ODP3	3 Step	720mm	25kg
ODP4	4 Step	950mm	29kg
ODP5	5 Step	1210mm	33kg
ODP6	6 Step	1450mm	36kg
ODP7	7 Step	1690mm	44kg
ODP8	8 Step	1930mm	45kg
ODP9	9 Step	2170mm	49kg
ODP10	10 Step	2410mm	55kg
ODP11	11 Step	2650mm	60kg



BAILEY Aluminium Access Platform Ladder - 200kg

Manually operated braking system.
Large 125mm wheels for portability and easy glide action.
100mm deep treads improve safety and comfort when climbing.
Work from three sides on the large, stable work platform, shelf included.
Supplied as a flat pack for optimal transporting, assembly required.
Made to Australian & New Zealand standards AS/NZS 1892.

Model	Type	Platform Height	Weight
FS13591	3 Step	828mm	38.1kg
FS13592	4 Step	1104mm	40.6kg
FS13593	5 Step	1381mm	43.0kg
FS13594	6 Step	1656mm	46.0kg
FS13595	7 Step	1933mm	48.5kg
FS13596	8 Step	2209mm	51.0kg
FS13597	10 Step	2761mm	62.0kg
FS13598	12 Step	3313mm	69.0kg
FS13599	14 Step	3866mm	76.4kg



BAILEY Aluminium Modular Access / Platform Ladder - 200kg

The modular access system is industrial rated for use on commercial and industrial sites.
Strong, fully welded design fabricated from heavy duty aluminium.
The access system is designed for high frequency, heavy duty use.
Highly manoeuvrable and lightweight.
The off-the-shelf solution means no lengthy lead times.
Removable handrails for safe access to the work zone.
Foot operated castors break for stability.
Supplied as a flat pack for optimal transporting.
Standard sized fasteners and included tools for improved assembly time.
Easy to follow picture-based instructions with actual size bolt template.
Made to Australian & New Zealand standards AS/NZS 1892.

Model	Type	Platform Size	Weight
FS13789	4 Step	1000mm	16.5kg
FS13790	4 Step	2000mm	31.0kg



StockMaster Navigator

Automatic braking.
Fast repositioning
Highly manoeuvrable.
Automatic safety gate at platform entry.
Side opening rota-gate for easy stock picking.



Model	Height	5kg Working Range	20kg Working Range
SMN04	1145mm	1400 - 2800mm	1400 - 2300mm
SMN05	1435mm	1700 - 3100mm	1700 - 2600mm
SMN06	1720mm	2000 - 3400mm	Not Suitable
SMN07	2005mm	2300 - 3700mm	Not Suitable
SMN08	2295mm	2500 - 3900mm	Not Suitable
SMN09	2580mm	2800 - 4200mm	Not Suitable
SMN10	2865mm	3100 - 4500mm	Not Suitable
SMN11	3155mm	3400 - 4800mm	Not Suitable
SMN12	3440mm	3700 - 5100mm	Not Suitable
SMN13	3735mm	4000 - 5400mm	Not Suitable
SMN14	4015mm	4300 - 5700mm	Not Suitable

StockMaster Step Thru

Mobile access steps for indoor and outdoor use.
Provides safe flexible access for container loading, transport vehicles, loading docks and mezzanine floors.
Moves easily over sealed or unsealed surfaces and slopes.
150kg load rating.

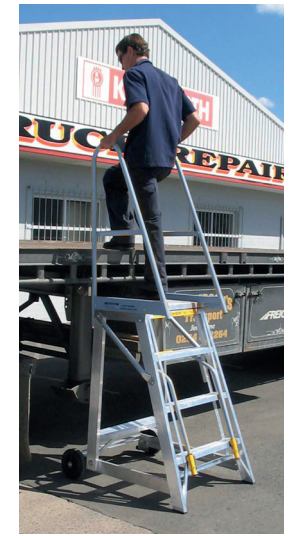

Model	Platform Height	Service Height Range
SM-ST03	860mm	900 - 1185mm
SM-ST04	1145mm	1185 - 1475mm
SM-ST05	1435mm	1475 - 1760mm
SM-ST06	1720mm	1760 - 2045mm
SM-ST07	2005mm	2045 - 2335mm
SM-ST08	2295mm	2335 - 2620mm
SM-ST09	2580mm	2620 - 2905mm
SM-ST10	2865mm	2905 - 3150mm

StockMaster LiftTruk

Lifts up to 60kg.
No battery required.
Greatly improves safety.
Available - PRO Version with Safety Gate and Rota Gate.



Model	Height	5kg Working Range	20kg Working Range
SMLT04M	1145mm	1400 - 2800mm	1400 - 2300mm
SMLT05M	1435mm	1700 - 3100mm	1700 - 2600mm
SMLT06M	1720mm	2000 - 3400mm	2000 - 2900mm
SMLT07M	2005mm	2300 - 3700mm	2300 - 3200mm
SMLT08M	2295mm	2500 - 3900mm	2500 - 3400mm
SMLT09M	2580mm	2800 - 4200mm	2800 - 3700mm
SMLT010M	2865mm	3100 - 4500mm	3100 - 4000mm
SMLT011M	3155mm	3400 - 4800mm	3400 - 4200mm
SMLT012M	3440mm	3700 - 5100mm	3700 - 4600mm
SMLT013M	3735mm	4000 - 5400mm	4000 - 4900mm
SMLT014M	4015mm	4300 - 5700mm	4300 - 5200mm

StockMaster Mezzalad

Personnel access ladder for access to mezzanines, lofts and other elevated work and storage areas.
Stores flat against the wall and is brought to the use position with a simple lift and pull.
Includes a safety gate at the upper floor level.

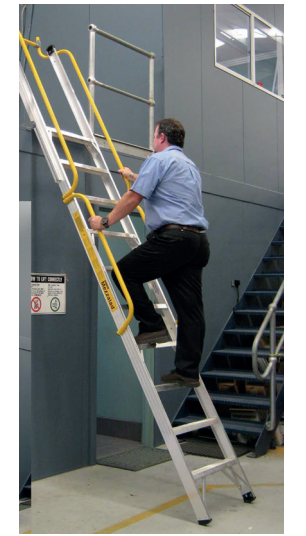

Model	Minimum Service Height	Maximum Service Height
SM-VH01	2330mm	2529mm
SM-VH02	2529mm	2744mm
SM-VH03	2744mm	2977mm
SM-VH04	2977mm	3225mm

StockMaster Tracker

Lifts up to 60kg.
No Battery Required.
Greatly Improves Safety.
Available - PRO Version with Safety Gate and Rota Gate.

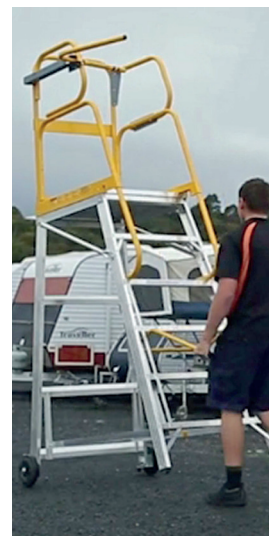

Model	Height	Working Range
SMT03	860mm	1100 - 2700mm
SMT04	1145mm	1400 - 3000mm
SMT05	1435mm	1700 - 3300mm
SMT06	1720mm	2000 - 3600mm
SMT07	2005mm	2300 - 3900mm
SMT08	2295mm	2900 - 4200mm
SMT09	2580mm	2800 - 4400mm
SMT10	2865mm	3100 - 4700mm
SMT11	3155mm	3400 - 5000mm
SMT12	3440mm	3700 - 5300mm
SMT13	3735mm	4000 - 5600mm
SMT14	4015mm	4300 - 5900mm

StockMaster Mezzalift

Manually operated Goods Lift for transfer of single items or stacked loads to Mezzanine floors and other Elevated Work and Storage areas.
Maximum recommended load 60kg.
Adjusts in length to suit the height of the mezzanine.

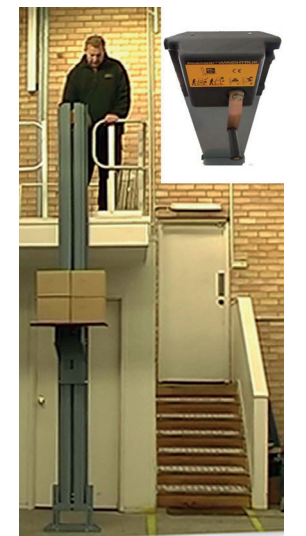

Model	Service Height Rating
SM-MH08	2250 - 2555mm
SM-MH09	2535 - 2840mm
SM-MH10	2820 - 3125mm
SM-MH11	3110 - 3415mm
SM-MH12	3395 - 3700mm
SM-MH13	3685 - 3990mm
SM-MH14	3970 - 4275mm

WORK PLATFORMS

These Team Systems Work Platforms are the only safe and authority approved way of lifting personnel to a height when using a forklift.



APPROVED PERSONNEL PLATFORM!

TSWP

Work Platform

Manufactured to meet Australian Standards - AS-2359.1.
 Designed to carry 2 people & up to 250kg.
 1200 X 1200 x 1000mm with 2200mm safety screen.
 Toe boards on all sides.
 Full length fork sleeves with skid resistant floor plates.
 Inward opening self closing door and internal hand rail.
 Safety chains fitted, 40mm square tube construction.
 Pins supplied for attaching to fork.
 Two harness anchor points.
 Precision made quality construction.
 Australian made.



BH01151

Optional Safety Harness

Energy Absorbing 2.0m Lanyard.
 Particularly suited to the hire industry.
 Fall/Arrest 136kg.
 Only available for use on fully welded work platform as per the TSWP pictured here.
 NOTE: The use of a safety harness is not mandatory with this platform.



FOLDS AWAY IN ONLY 5 MINUTES!

TSWPF

Collapsible Work Platform

250kg Rating
 Stores & assembles with ease.
 Ideal for freighting.
 Complies with Australian Safety Standards - AS-2359-1.
 Comes ready to use.

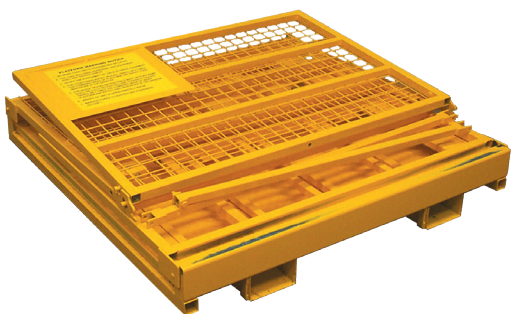

LADDER & ACCESS EQUIPMENT